

# A guide to using the OSU Libraries

## Edmon Low Library Floor Maps

### KEY

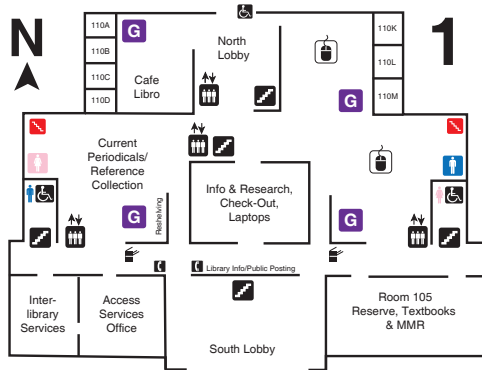

### 1st floor

- The floor has public computers and is a Group Study Area. Current periodicals are shelved in the northwest.
- Librarians at the Information & Reference Desk can answer questions help locate materials.
- The Circulation Desk will check out books and make room reservations. Pick up ILS requests here.
- At the Laptop Desk you can check out laptops and iPads.
- The Room 105/MMR contains multimedia readers and material. It also houses hard copy reserve items such as textbooks.
- Interlibrary Services (ILS) borrows books and journal articles from other libraries. Request forms are on the website.
- Cafe Libro is located in the North Lobby. You can buy specialty coffee, snack items and sandwiches.
- The Thompkin-McCollom Room (102K), 102L, The Dean & Carol Stringer Room (102M), 110A, 110B, 110C and 110D are available for use by individuals and small groups. Make reservations at the Circulation Desk.

### KEY

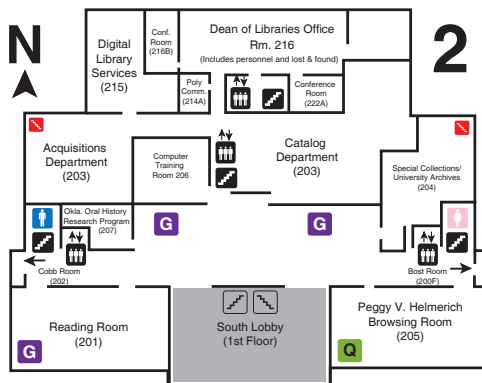
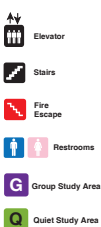

### 2nd floor

- The Peggy V. Helmerich Browsing Room is a Quiet Study Area. It also contains publications about Oklahoma.
- Special Collections/University Archives contains rare books, manuscripts and an OSU collection.
- The Paul Miller Room is a public area which can be used to browse Special Collections/University Archives material.
- The Bost and Cobb Rooms are available for use by individuals and small groups. Make reservations at the Circulation Desk.
- Room 206 is a computer training facility. Librarians teach Catalog and Internet classes here.
- Oversized Books are shelved in the Reading Room, a Group Study Area.



Oklahoma State University  
Library

Contact for information:  
Reference Desk  
Phone: 405-744-9775  
Text: 405-301-8102

# A guide to using the OSU Libraries

## KEY

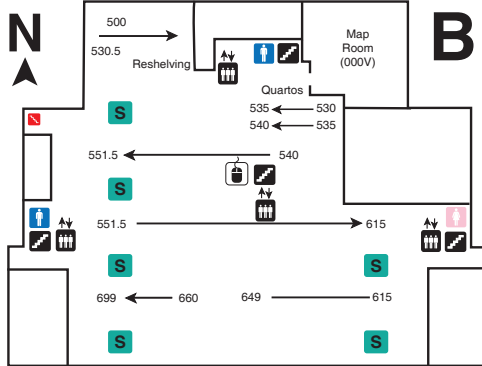
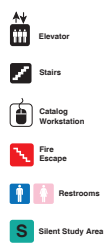

## Basement

- The Map Room has sheet maps, aerial photographs, and city and state maps.
- Books and bound journals with call numbers 500-649 & 660-699 are shelved on this floor.
- The Basement is a Silent Study Area.

## KEY

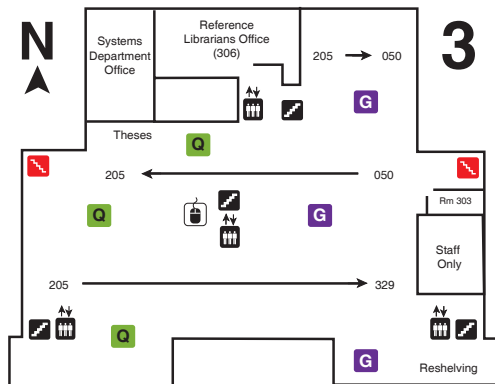

## 3rd floor

- Reference Librarians Offices are found on the north side.
- Books and bound journals with call numbers between 000-329 are shelved on this floor.
- The west end of the floor is a Quiet Study Area; the east end is a Group Study Area.

## KEY

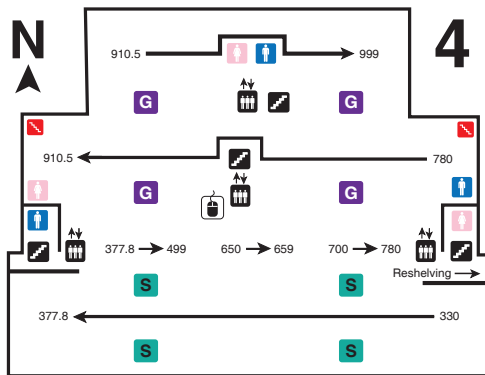

## 4th floor

- Books & bound journals with call numbers 330-499, 650-659, & 700-999 are shelved on this floor.
- A Silent Study Area is located on the south half of the floor; Quiet Study Area is on the north half.

## KEY

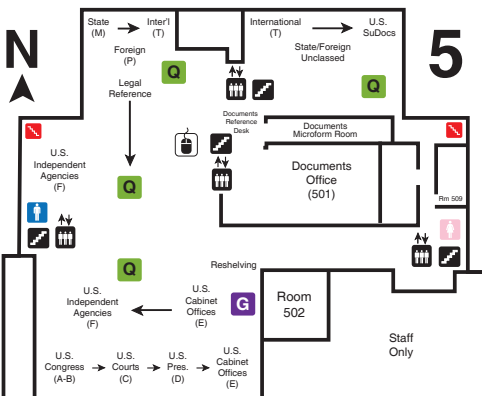

## 5th floor

- The Documents Department has federal, state, city and foreign government publications. It also includes publications from international organizations such as the World Bank and the International Monetary Fund.
- Legal reference materials are located here.
- The north end of the Documents section is a Quiet Study Area. There is a small Group Study Area in the southeast corner.